



NEUMASEM PLUS DRILL CONTROL



MAQUINARIA AGRICOLA SOLA,S.L.
Ctra. de Igualada s/n. Apdo.Correos,11
08280 CALAF (Barcelona) ESPAÑA
Tel. 34 93 868 00 60*
Fax. 34 93 868 00 55
www.solagrupo.com
e-mail:sola@solagrupo.com

USER GUIDE

Electro-Magnetic Compatibility (EMC)

This product complies with Council Directive 2004/108/EC when installed and used in accordance with the relevant instructions.



Service and Technical Support

PLEASE CONTACT YOUR NEAREST DISTRIBUTOR
If unknown then fax: 44 (0) 1453 733322

© Copyright RDS Technology Ltd 2006

Our policy is one of continuous improvement and the information in this document is subject to change without notice. Check the software reference matches that displayed by the instrument.

Document number
S/DC/500-10-537 : Issue 1 : 12/1/06

UK537-1.DOC

User Guide

SOLÁ

Neumasem Plus Drill Control

Calibration and Operation
Software Ref: WZ 813-001 rev.01

Contents

Contents	2
1. Overview	4
Normal Display Mode	4
Programming Modes	4
2. The Control Switches	5
3. Forward Speed	6
Display Forward Speed	6
Forward Speed Alarm	6
Disable Forward Speed Alarm	6
Speed Sensor Calibration	7
'Autocal'	7
4. Area Total / Implement Width	9
Display Area Total	9
Reset Totals	9
View/Set Implement Width	10
View/Set Left/Right Wing Width	10
View/Set Full Width	10
5. Tramlining	11
Manually advance the bout number	11
Hold the bout number	11
Symmetric Tramlining Sequence	12
Asymmetric Left Tramlining Sequence	13
Asymmetric Right Tramlining Sequence	14
10-Bout Tramlining Sequence	15
18-Bout Tramlining Sequence	16
Selecting the Tramline Sequence	17
Setting the Tramline Bout	17
6. Fan Speed / Speed Alarms	18
Display Fan Speed	18
Fan Speed Alarms	18
Set Low Fan Speed Alarm	18
High Fan Speed Alarm	19

7. Seed Distribution Shaft Speed	20
Display Shaft Speed	20
Distribution Shaft Speed Alarm	20
Set Alarm Speed for Distribution Shaft	20
8. Hopper Level	22
Enable / Disable Hopper Level Alarm	22
9. Summary of Programme Modes 1 – 3	23
Document History	24

1. Overview

The *Sola Neumasem Drill Control* monitors several functions of the seed drill, sets the seeding width, and controls the tramlining function of both conventional and pneumatic type seed drills. The instrument has an illuminated 4-digit display with 6 display functions and alarm functions for forward speed, fan rpm, seed distribution shaft rpm and hopper level.

The speed and area functions are displayed in metric units.

The instrument indicates;

- Forward Speed (plus low speed alarm)
- Part Area and Total Area worked
- The current bout number and tramline bouts for the selected tramlining sequence.
- Fan rpm (plus low/high speed alarm)
- Seed Distribution Shaft rpm (plus low speed alarm)
- Hopper level low (plus alarm)

There are two memory registers (Total 1 and Total 2) to record area worked. The area is accumulated to both memory registers. Area totals and all calibration data are automatically stored in memory when the instrument is powered off.

The instrument also indicates whether seeding at part width or full width, or that the micro-metering ratio (for small seed) is in effect.

Normal Display Mode

The instrument has a normal display mode displaying the work functions. Select a channel by pressing the  button once or more.

When the drill is moving, the selected channel is displayed for 10 seconds before defaulting back to the tramline display ( channel).

Programming Modes

There are 2 programming modes with various calibration factors and default settings.

Many of these settings are made on installation and do not normally need to be changed unless the instrument is switched onto a different drill. These settings are appended to the back of this manual. The operator does not normally need to refer to them.

2. The Control Switches

There are five switches on the front panel used individually or in combination to select, programme, or reset a function.

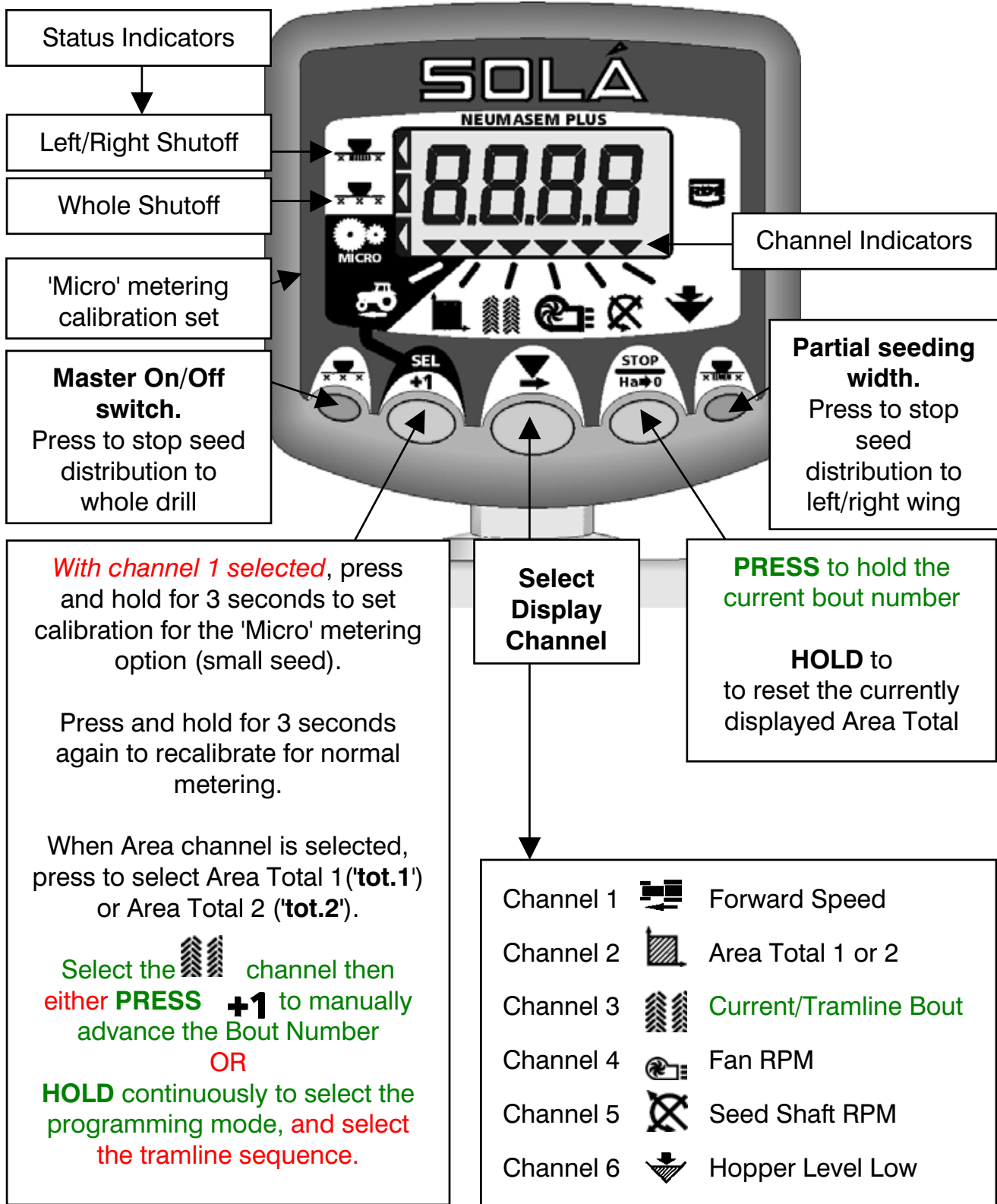

3. Forward Speed

Display Forward Speed



Forward Speed displays for 10 seconds before returning to the tramline display.

If an alarm condition occurs, the display will default to the appropriate channel, the buzzer will sound 5 beeps, and the display will remain flashing on that channel until either,

- (i) the alarm condition is rectified.
- (ii) the forward speed drops below 2km/h.
- (iii) another channel is selected and the alarm ignored.

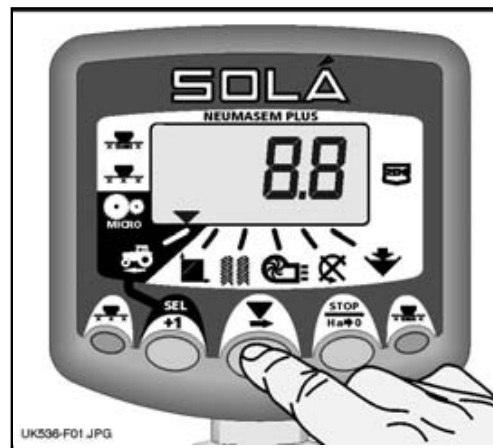



Figure 1: Display Forward Speed

Forward Speed Alarm

If you stop while the drill is in work, then the instrument will beep twice, and the display will alternate between '0.0' and 'ALAR'

This continues until the speed is increased above the 2.0 km/hr threshold.

Disable Forward Speed Alarm

1. Press and hold  whilst switching on the instrument to enter programme mode 2. The display should show '1' indicating the alarm is enabled.
2. Press  to set '0' and disable the alarm.
3. Switch the instrument off and on again to resume normal operating mode.

FORWARD SPEED C1

Select the channel with the central button. Under 2.6 km/h the alarm rings. You can deactivate this alarm by entering in programme 2.

Speed sensor calibration

Enter a calibration factor in programme 2, following this panel:

MODEL	400	450	500	600
CALIBRATION FACTOR	1.818	1.574	1.449	1.258

1. Select the speed channel. (C1)
2. Press "SEL" to enter in rate 1. Keep pressing and press the central button (v) to change the digit to modify.
3. Keep the central button pressed for some seconds to modify the digit's moving value. Leave the value on the screen.
4. Stop pressing the buttons and the monitor will return to normal position.

The S.S.F. is normally calculated automatically via the "Autocal" function.

'Autocal'

For maximum accuracy, perform an auto-calibration in field conditions.

NOTE: The seed shaft gear ratio must be set for normal seed i.e. not set for 'micro' metering. If the gearing is set to the 'micro' ratio, speed calibration will be incorrect resulting in incorrect forward speed display and area accumulation when set at the normal metering ratio.



1. Set two markers at 100 metres apart (328 feet). Choose a convenient reference point on the tractor/implement and position this point opposite the first marker.
2. Select the  channel.
3. HOLD  until the existing calibration factor is displayed.
4. Continue holding this button and press 
The display flashes 'Auto' ready for calibration.



Figure 2: Start 'Autocal'

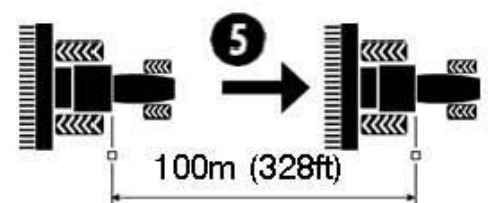



Figure 3: 'Autocal' distance

5. Drive the vehicle until the chosen reference point on the tractor/implement is opposite the second marker.

The instrument counts and displays the sensor pulses received over the distance travelled.

6. Press the  button to complete the Autocal routine (fig. 4).

The calibration factor is automatically calculated and stored in memory.

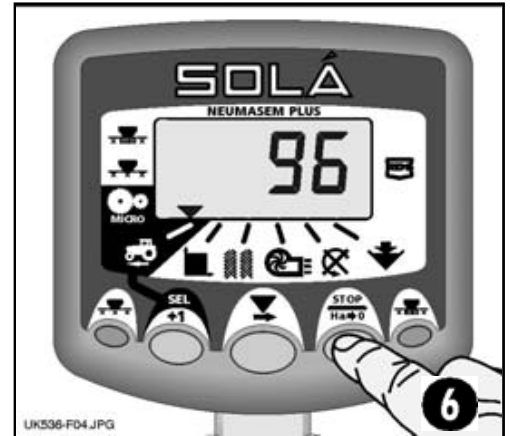

Figure 4: Stop 'Autocal'

4. Area Total / Implement Width



The area is derived from the forward speed and the programmed implement width and is accumulated to whichever total is selected on the display – total 1 or total 2.

Area will only accumulate while the drill is in work, i.e. forward speed is being registered, and is automatically calculated based on the seeding width selected.

The two separate area totals can be independently reset to zero.

Display Area Total



1. Select the  channel.
2. Press  to cycle between the two area totals.

The display will then show 'tot.1' or 'tot.2' before displaying the area accumulated since that total was last reset.

Area total displays for 10 seconds before returning to the **tramline** display.

Reset Totals



1. Select the  channel.
2. Press  to cycle between the two area totals.
3. Hold  for 5 seconds to zero that total.



Figure 5: Display Area Total



Figure 6: Select Total 1 or Total 2









Figure 7: Reset Total

View/Set Implement Width

In order for the instrument to accumulate area correctly, the implement working width must be programmed. The units are in metres.

View/Set Left/Right Wing Width

1. Select the  channel.
2. Press  to select left/right wing shutoff as shown by the left top indicator (fig. 8).
3. HOLD  to enter programme mode 1.
After 5 seconds the current wing width is displayed with the first digit flashing.
4. To change the value, continue holding the button and...
5. PRESS  to select the digit or decimal point to change.
6. HOLD  to change the selected digit (or move the decimal point).
7. RELEASE  to select the next digit and repeat as above, otherwise simply release both buttons. The instrument will then return to the normal display mode.

View/Set Full Width

As above except first press  to select full width shutoff as shown by the left middle indicator (fig. 10).



Figure 8: View Wing Width



Figure 9: Set Wing Width

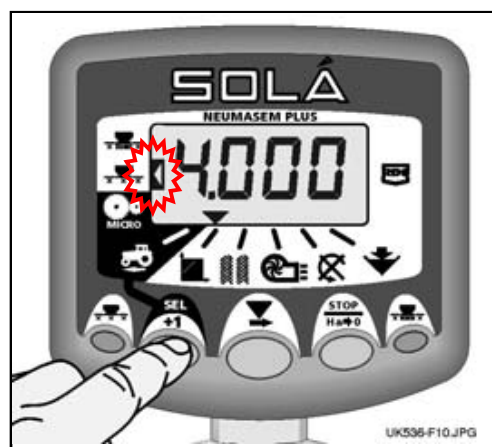

Figure 10: Set Full Width

5. Tramlining

The display defaults to the  channel after 10 seconds (unless the Area Total was selected).

There are five systems of tramlining - symmetric, asymmetric left, asymmetric right, 10 bout and 18 bout. The tramline bout is programmable from 1 to 15 in symmetric, asymmetric left and asymmetric right sequences.

Selection of asymmetric tramlining is denoted by a decimal point on the display between the current bout number on the left and the tramline bout number on the right. Left or right asymmetric tramlining is selected in the programming mode.

NOTE: There is an option in the programme mode to disable the tramline function altogether.

Manually advance the bout number

Press  to advance the current bout number by 1.

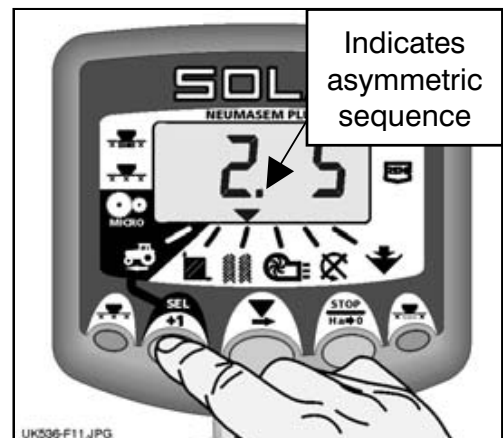



Figure 11: Advance bout number

Hold the bout number

Press  to 'hold' the current bout when the drill goes out of work.

The display will flash 'StOP'.

Press  again to resume the normal bout sequence.

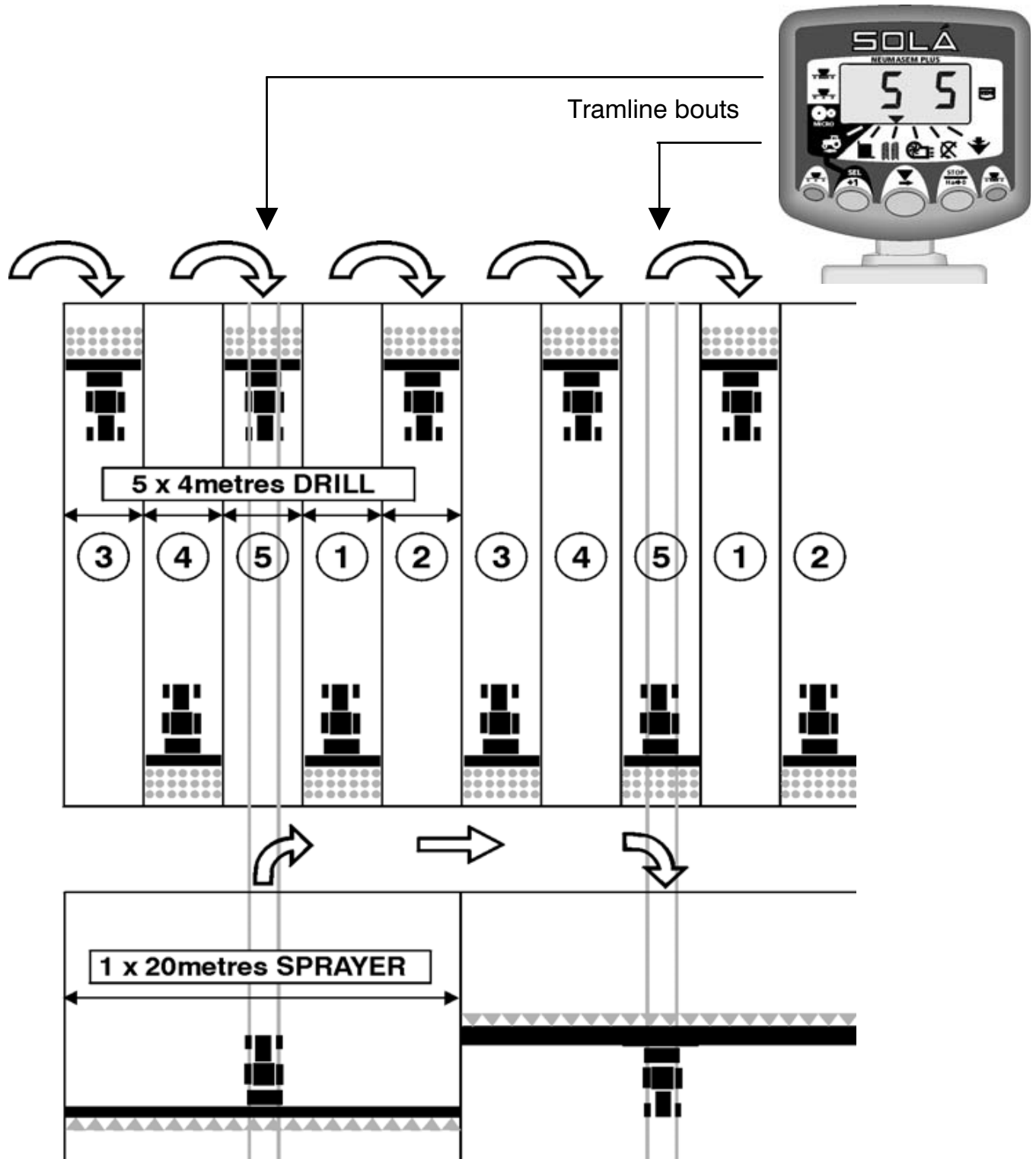

Figure 12: Hold bout number

Symmetric Tramlining Sequence

2+2 seed spouts are closed during the tramline bout only.

The instrument will beep once at the beginning of the tramline bout, and the display will continue flashing for the duration of the bout.



Asymmetric Left Tramlining Sequence

Two seed spouts are closed on the **left hand side** of the drill on the tramline bouts.

The instrument will beep once at the beginning of each tramline bout, and the display will continue flashing for the duration of the bout.

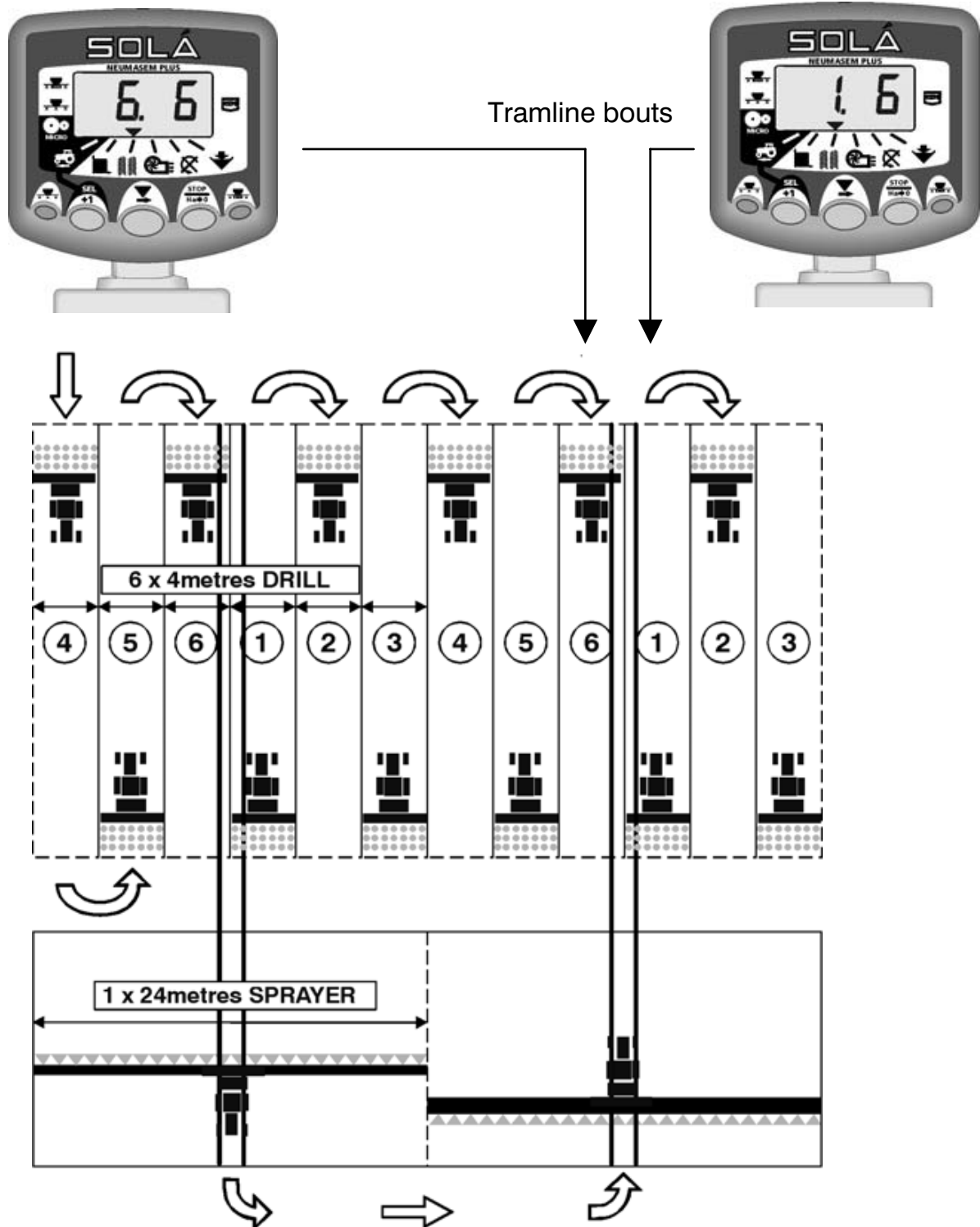

Asymmetric Right Tramlining Sequence

Two seed spouts are closed on the **right hand side** of the drill on the tramline bouts.

The instrument will beep once at the beginning of each tramline bout, and the display will continue flashing for the duration of the bout.

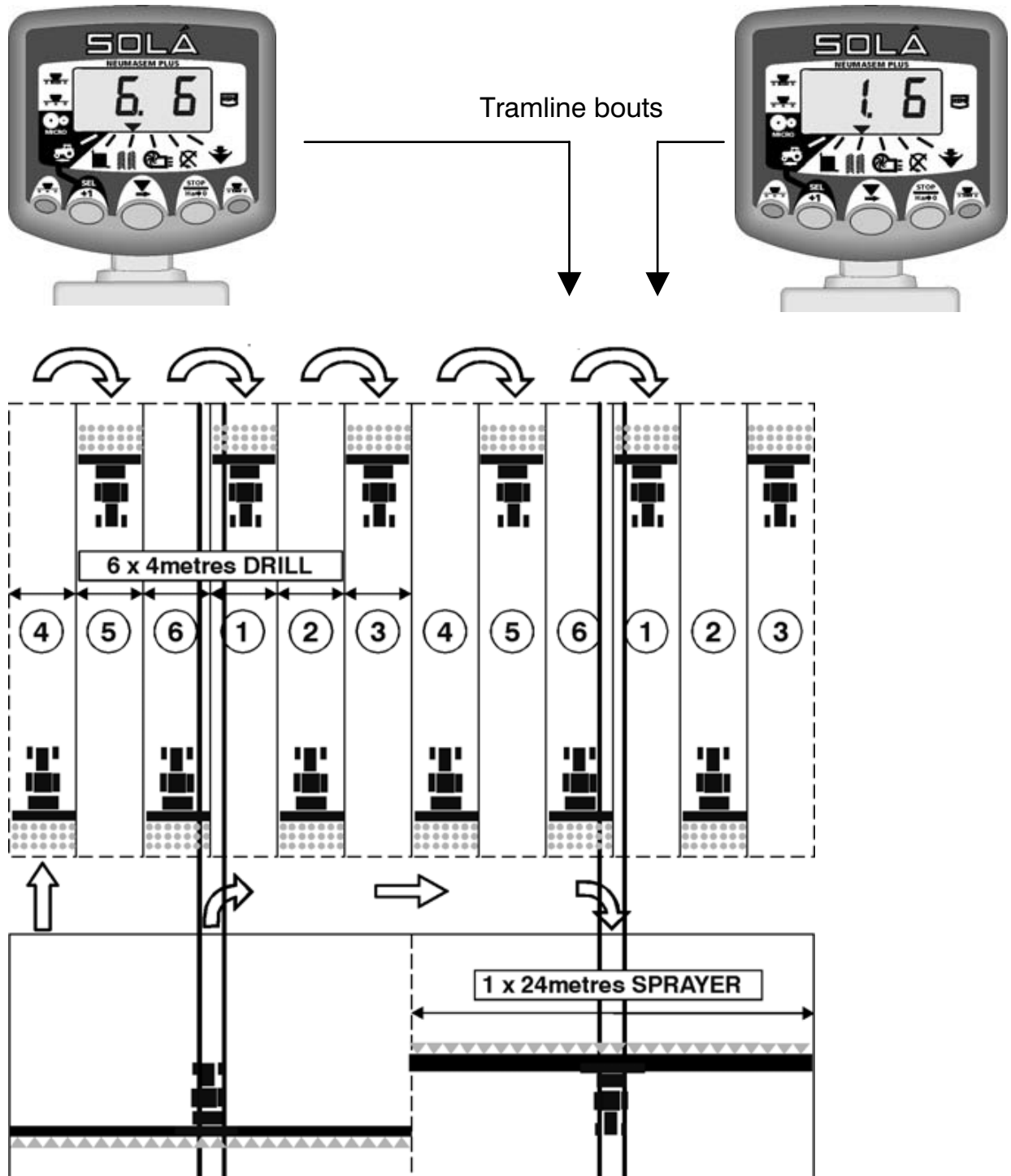

10-Bout Tramlining Sequence

For use with 4 metre drill/10 metre sprayer, or 8 metre drill/20 metre sprayer combinations. (2 x 2 left hand seed spouts are closed on bouts 4 and 7, and 2 x 2 right hand seed spouts closed on bouts 2 and 9). Starting on bout 1 requires turning **RIGHT** at the end of the first bout.

NOTE: To turn LEFT at the end of the first bout, advance the bout number to 6 before commencing drilling.

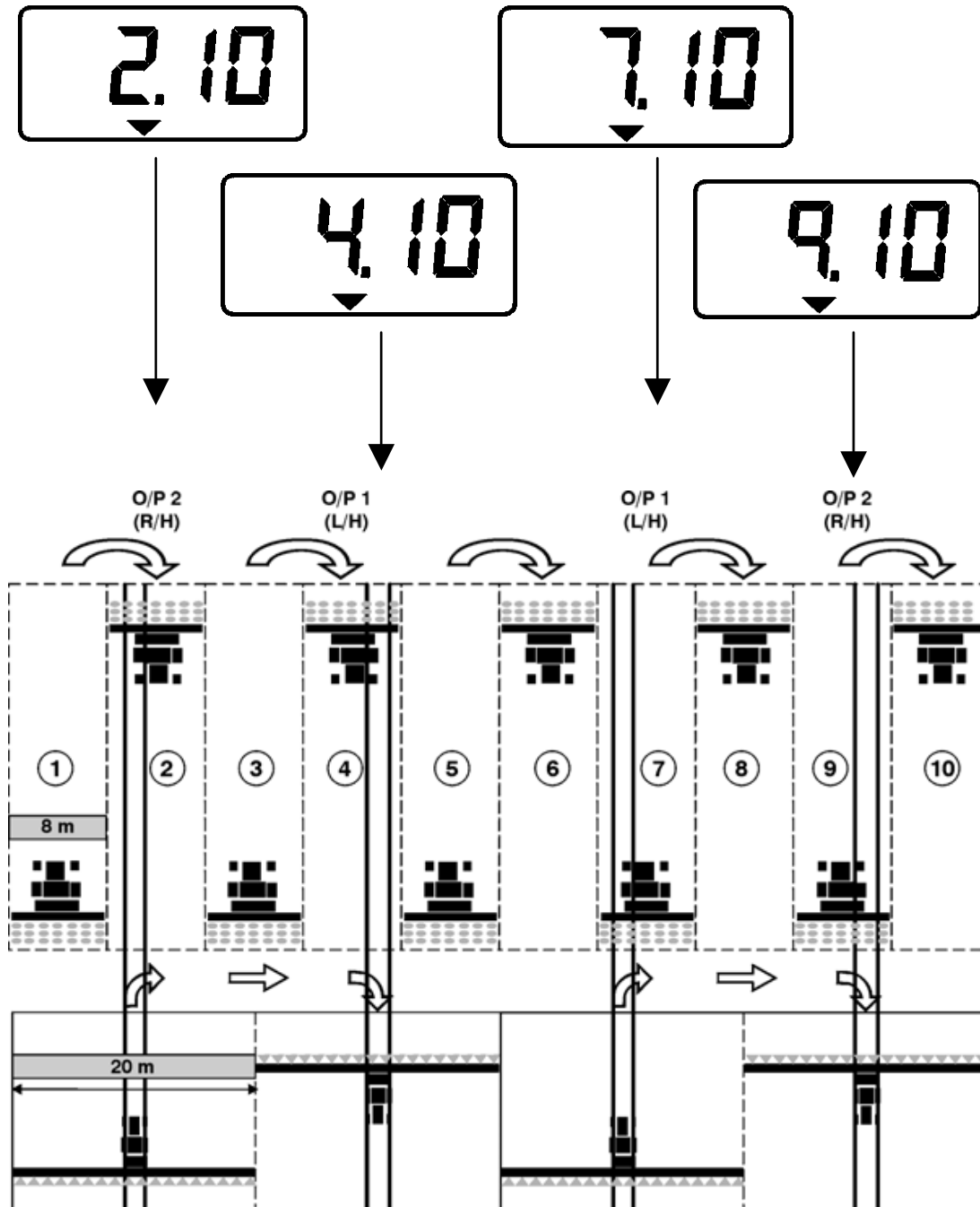

18-Bout Tramlining Sequence



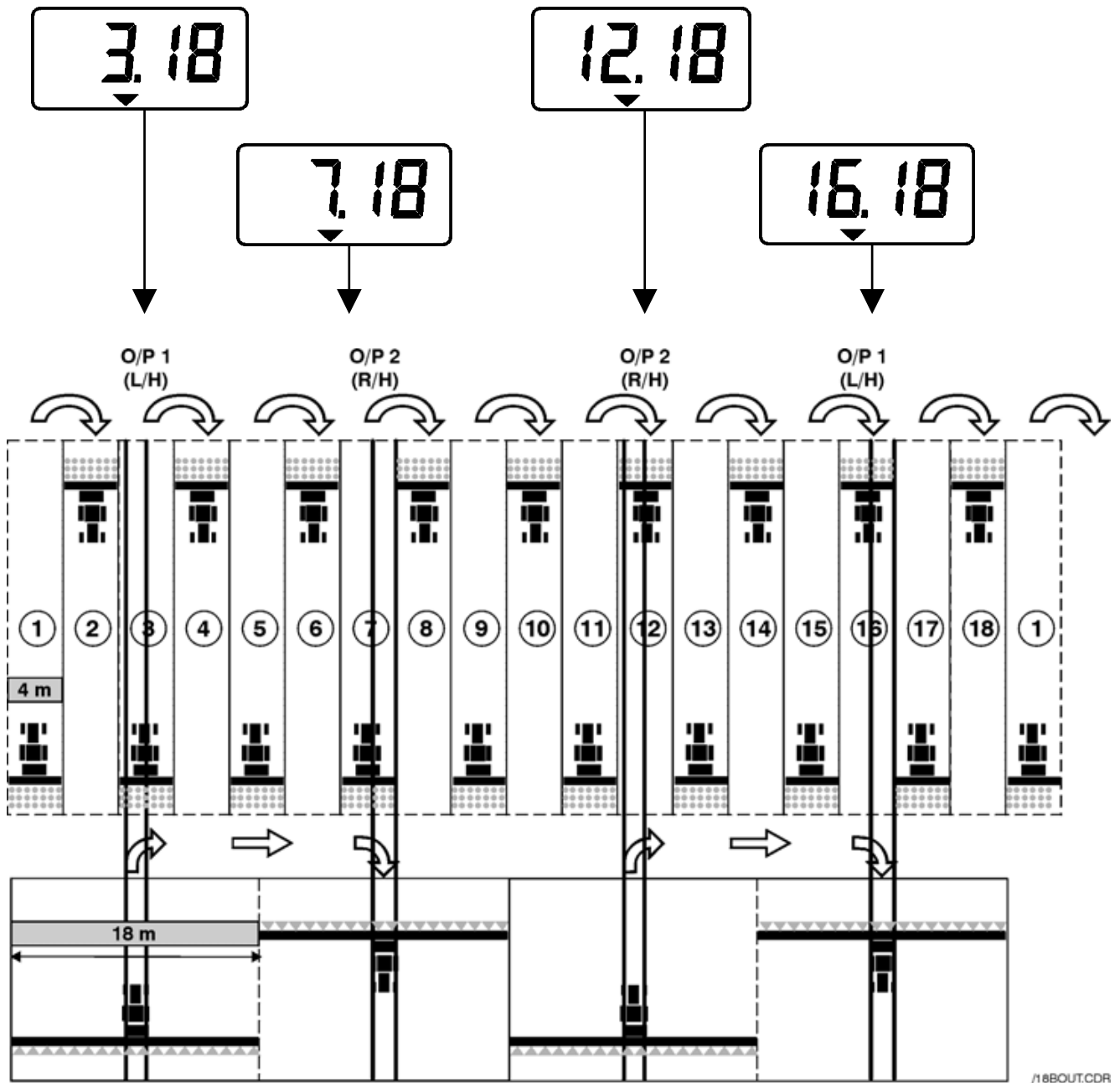

For use with a 4 metre drill and an 18 metre sprayer. (2 x 2 left hand seed spouts are closed on bouts 3 and 16, and 2 x 2 right hand seed spouts closed on bouts 7 and 12). Starting on bout 1 requires turning **RIGHT** at the end of the first bout.

NOTE: To turn LEFT at the end of the first bout, advance the bout number to 10 before commencing drilling.

The instrument will beep once at the beginning of each tramline bout and the display will flash for the duration of the tramline bout.



Selecting the Tramline Sequence

1. Select the  channel.
2. Hold  to enter programme mode 1.
After 5 seconds the first two digits flash, indicating the tramline sequence currently set:-
'SY' = Symmetric
'AL' = Asymmetric Left
'Ar' = Asymmetric Right
'AS' = Special Asymmetric sequences e.g. 10 bout and 18 bout.
3. Continue holding the  button and press and HOLD the  button to select the required sequence.

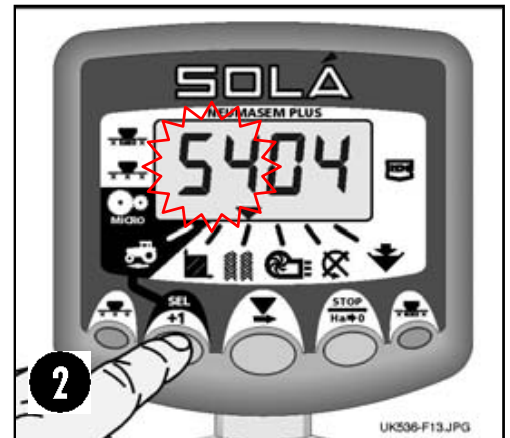



Figure 13: Tramline Sequence

Setting the Tramline Bout

4. PRESS and RELEASE the  button to toggle between the tramline sequence and tramline bout number display.
The 3rd and 4th digits flash indicating the tramline bout number currently set.
5. PRESS and HOLD the  button to cycle the tramline bout from 1 to 15.
NOTE: If either asymmetric left ('AL') or asymmetric right ('Ar') sequences are selected, the tramline output is also switched on for the bout following the target bout (i.e. bout 1).
If the special asymmetric sequence ('AS') is selected, the only options for the tramline bout number are 10 and 18.

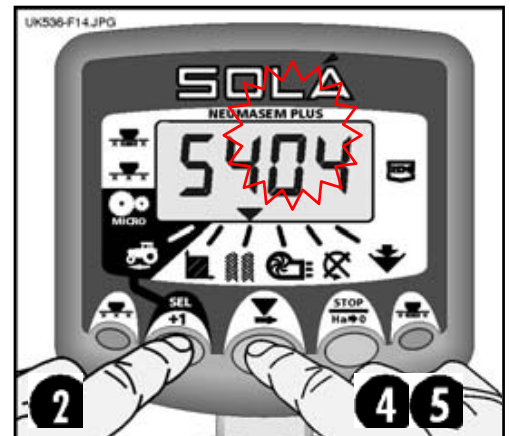

Figure 14: Tramline Bout Number

6. Fan Speed / Speed Alarms

Display Fan Speed



Select the  channel.

Fan Speed displays for 10 seconds before returning to the **tramline** display.

Fan Speed Alarms

There is a programmable **low**-speed alarm and a **non**-programmable **high** speed alarm. An alarm condition causes the instrument to default to the fan speed channel, sound 5 beeps and flash the actual fan speed. The audible alarm will continue to sound every 30 seconds until the alarm condition is resolved.



NOTE: The alarm is temporarily inhibited if another channel is selected, or if the forward speed is less than 2 km/hr.

Thresholds: Low speed = 2700 rpm (default), High speed = 5000 rpm



Figure 15: Display Fan Speed

Set Low Fan Speed Alarm

1. Select the  channel.
2. Hold  to enter programme mode 1.
The alarm threshold is displayed after 5 seconds. Continue holding the button and...
3. PRESS  to select the digit or decimal point

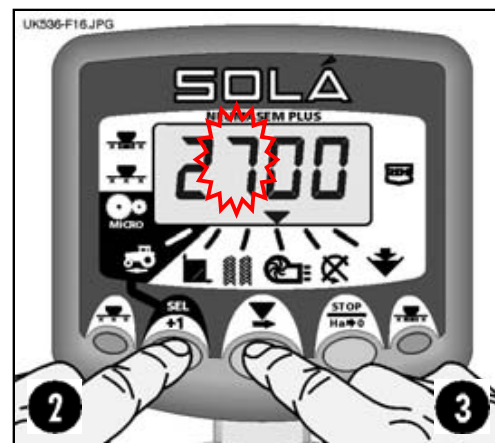



Figure 16: Low speed alarm threshold

4. HOLD  to change the selected digit (or move the decimal point).
5. RELEASE  to select the next digit and repeat as above, otherwise simply release both buttons. The instrument will then return to the normal display mode.

High Fan Speed Alarm

The high speed alarm is set at 5000 rpm and is not programmable.

7. Seed Distribution Shaft Speed

Display Shaft Speed



Select the  channel.

Shaft Speed displays for 10 seconds before returning to the **tramline** display.



Figure 17: Distribution Shaft speed



Distribution Shaft Speed Alarm



The default alarm setting is 0 rpm. When set >0 , and the seed shaft rpm goes below the threshold or stops, the instrument will sound 5 beeps and will default to the  channel from the current channel selected.

The audible alarm will continue to sound every 30 seconds until the alarm condition is resolved.

NOTE: The alarm is temporarily inhibited if another channel is selected, or if the forward speed is less than 2 km/hr.

Set Alarm Speed for Distribution Shaft

1. Select the  channel.
2. Hold  to enter programme mode 1.
The alarm threshold is displayed after 5 seconds. Continue holding the button and...
3. PRESS  to select the digit to change.

4. HOLD  to change the selected digit.
5. RELEASE  to select the next digit and repeat as above, otherwise simply release both buttons. The instrument will then return to the normal display mode.

NOTE: Setting '0' disables the alarm function.

8. Hopper Level





This display is left blank if the alarm function is disabled in programme mode 1.

When the alarm is enabled, when the seed level drops below the sensor fitted in the side of the hopper, the instrument defaults to this channel and sounds 5 beeps



Figure 18: Hopper Low Alarm

Enable / Disable Hopper Level Alarm

1. Select the  channel.
2. Hold  to enter programme mode 1. Continue holding the button and...
3. PRESS  to select 0 (Off) / 1 (On).

The display will stay blank on this channel when the alarm is disabled.

4. Release both buttons. The instrument will then return to the normal display mode.



Figure 19: Disable Alarm

9. Summary of Programme

Most settings do not need to be accessed during normal. Default values shown in *[brackets]*.

		Programming mode 1	Programming mode 2	Programming mode s
	Operating Mode	Select channel, press and hold 'SEL/+1' to enter	Power on whilst holding 'SEL/+1' to enter mode. Use same key to select channel	Power on whilst holding 'STOP/HA-0' for 10 seconds to enter mode. Use same key to select channel
Channel 1	Forward Speed	Speed sensor factor & autocal	Forward speed alarm	
	(Km/h)	See tables	Default: 1 (on)	
Channel 2	Area x 2	Working width		Grand total area
	(Hectares)	See width		(Ha)
Channel 3	Tramlining	Tramline Sequence	Tramline option	
		Default: SY04	Default: 1 (on)	
Channel 4	Fan Speed	Low alarm speed	High alarm speed	Fan PPR
	(RPM)	Default: 3800 rpm	Default: 5000rpm	Default: 2.000
Channel 5	Shaft Speed	Low alarm speed		Shaft PPR
	(RPM)	Default: 0rpm		Default: 1.000
Channel 6	Hopper Alarm	Alarm on/off		
		Default: 1 (on)		

